

Target for TI C2000™ 2.2

Deploy embedded code onto TI C2000 processors

Target for TI C2000™ integrates MATLAB® and Simulink® with Texas Instruments eXpressDSP™ tools and C2000 processors. Together, these products let you develop and validate control designs and digital signal processing algorithms from concept through code by performing automatic code generation, prototyping, and embedded system deployment on TI C2000 processors.

By using Target for TI C2000 and your TI development tools together with Link for Code Composer Studio™, Real-Time Workshop®, and Real-Time Workshop® Embedded Coder (all available separately), you can generate a C-language real-time implementation of your Simulink model. Target for TI C2000 supports TI C281x and C280x 32-bit fixed-point DSPs and C240x 16-bit fixed-point DSPs. You can automatically compile, link, download, and execute the generated code on the F2808 eZdsp, F2812 eZdsp, or the F2407 eZdsp evaluation boards. Onboard DSP peripherals are directly supported. The generated code is readable and editable with Real-Time Workshop Embedded Coder.

Working with Target for TI C2000

You construct system models and real-time control algorithms within the Simulink environment, using blocks from the Simulink block library and from Simulink® Fixed Point and Signal Processing Blockset. You can then use Target for TI C2000 along with Link for Code Composer Studio to automate code generation, execution, and communication with TI evaluation boards by inserting blocks for optimized functions, together with the appropriate board peripherals, into your model.

KEY FEATURES

- Automates the execution, testing, verification, and validation of generated code on TI C2000 processors
- Enables real-time evaluation of system designs on F2808 eZdsp, F2812 eZdsp, and F2407 eZdsp boards
- Supports custom boards based on all DSP devices in C281x and C280x families
- Provides block-level access to on-chip peripherals, such as PWM, ADC, CAN, and target memory
- Provides block-level access to the TI IQMath and Digital Motor Control libraries for simulation and code generation
- Provides blocks for implementing real-time execution scheduling schemes for synchronous and asynchronous tasks
- Enables fixed-point system design, simulation, and scaling (with Simulink Fixed Point, available separately)
- Supports on-chip flash programming for C281x and C280x DSPs
- Provides C280x GPIO Digital Input and Output blocks for input and output capabilities

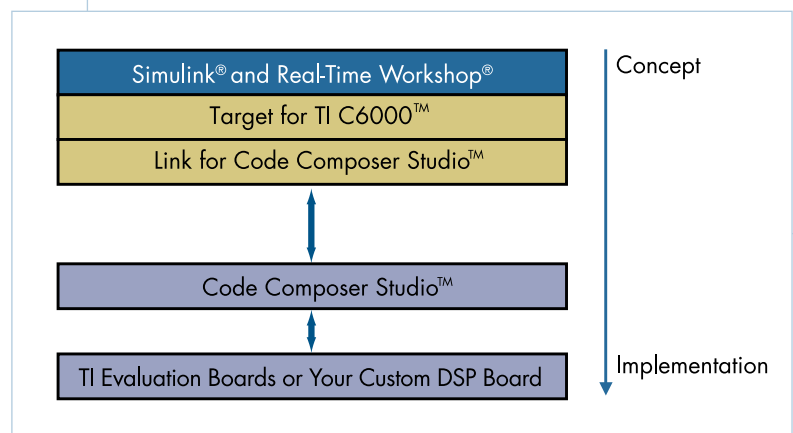

Simulink, RealTime Workshop, Target for TI C2000, and Link for Code Composer Studio provide an integrated platform for designing, simulating, implementing, and verifying embedded control systems on standard and custom TI C2000 processors.

Block Libraries

C2000 Target Preferences

C2400 DSP Core Support

C280x DSP Core Support

C281x DSP Core Support

C28x Digital Motor Control (DMC)

C28x IQMath Library

Host-side CAN Blocks

Host-side SCI Blocks

RTDX Instrumentation

Using the Core Support Library

The Core Support library for each supported DSP family—280x, 281x, and the 2400—provides blocks for I/O and communication and access to peripherals on the DSP or the board, such as eCAN, ePWM, eQEP, Read From Memory, and Write To Memory. The parameters for these blocks can be modified with Simulink dialog boxes. You can automatically generate prototype code for any of the supported boards, combining these blocks with standard blocks from Simulink, Simulink Fixed Point, and Signal Processing Blockset.

Target for TI C2000, together with Real-Time Workshop and TI development tools, automatically generates C code and builds an executable for the selected evaluation board. The build process can also download code to the evaluation board and run the executable on the target DSP. Support is provided for the execution of 16-bit C24x and 32-bit C28x fixed-point algorithms.

Using the Board Support Library

The board support blocks are parameterized with Simulink dialog boxes and provide access to I/O, peripherals, and other utilities on each of the supported boards. You can automatically generate prototype code for a supported DSK or EVM board, combining these blocks with standard blocks from Simulink and add-on blocksets.

Target for TI C2000, together with Real-Time Workshop, Link for Code Composer Studio, and TI development tools, automates the process of code generation, compiling, linking, downloading, and executing embedded signal processing applications on the DSK or EVM evaluation board.

Using the IQMath Library to Optimize Code

Target for TI C2000 gives you direct access to Texas Instruments C28x IQMath Library, a collection of optimized mathematical library functions for porting floating-point algorithms into fixed-point code on C28x devices. These functions are typically used in computationally intensive real-time applications that demand optimal execution speed and a high degree of accuracy. Using these routines, you can execute considerably faster than with equivalent ANSI C.

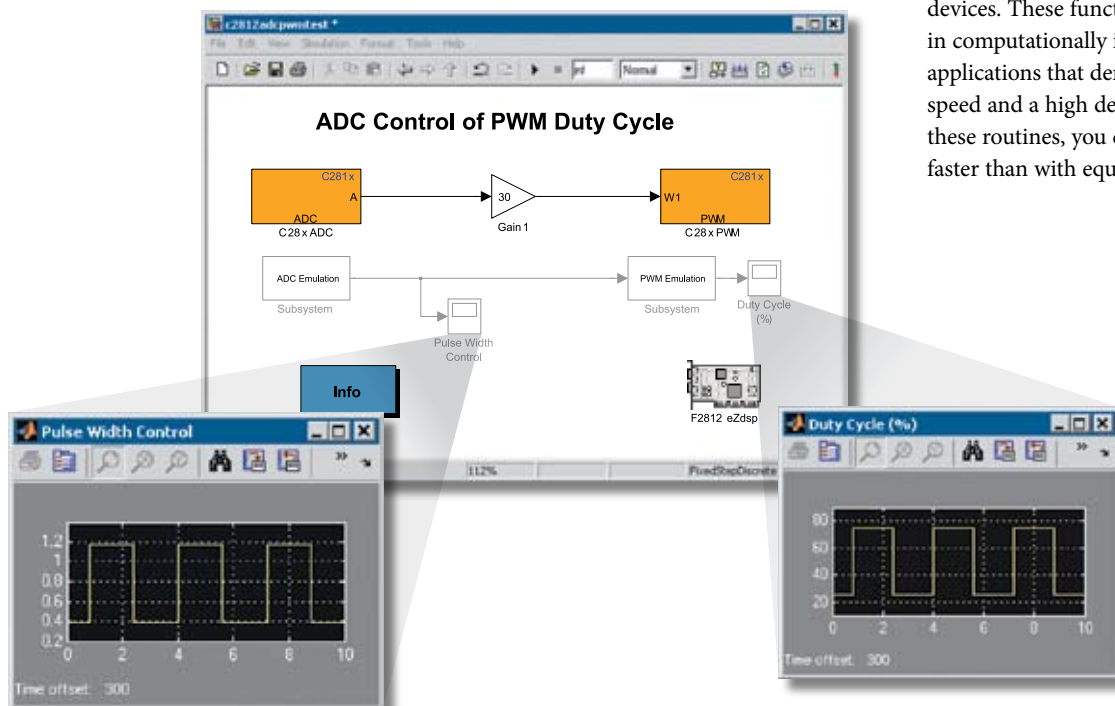

Controlling the PWM duty cycles of PWM peripherals using ADC input.

Using the Asynchronous Scheduler

The Asynchronous Scheduler lets you create multiple tasks, tie each task to a specific hardware interrupt, and use it to trigger the execution of a task. You can assign priority to each task, and specify that tasks with higher priority can interrupt lower-priority tasks at any time. This approach improves response times from your embedded application. It also lets you implement algorithms that could not be implemented on traditional periodic timer interrupts.

You can assign background tasks to run while the system is idle without the involvement of a hardware interrupt, enabling you to control the execution schedule for noncritical tasks. All non-reserved CPU and PIE interrupts are supported by the Asynchronous Scheduler. Logical interrupt priorities are assigned to each interrupt-driven task that you specify. The generated code automatically incorporates these priorities.

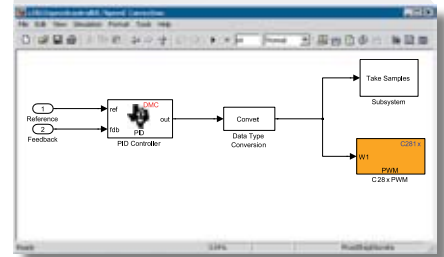
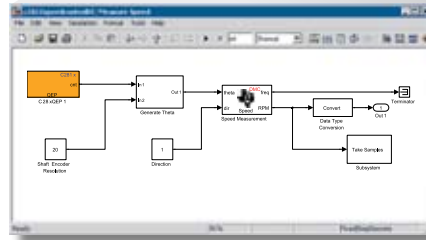
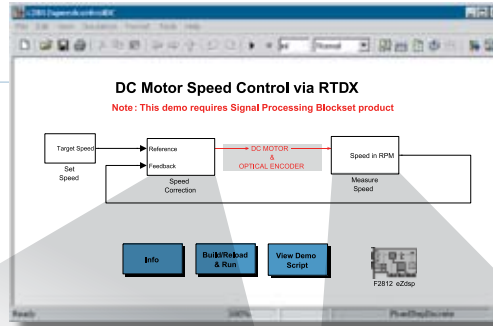

Closed-loop speed control of a DC motor using C28x peripherals and Digital Motor Control (DMC) library blocks. RTDX sends the desired speed of the motor, which you can set through a MATLAB graphical user interface (GUI), to the controller code running on the processor.

Designing Advanced Control Applications

Target for TI C2000 supports the design of advanced controllers with tools including:

- eCAN, eQEP, and ePWM, and other peripherals that let you configure and implement advanced embedded control systems

- Flash memory support, letting you automatically create and build a Code Composer Studio project suitable for download to the DSP flash memory through a Code Composer Studio flash-burn plug-in
- A custom target option, letting you generate code for your custom DSP board based on TI F28x, F281x, or 2400 DSPs
- Custom storage classes to force selected segments of generated code to occupy specific portions of memory

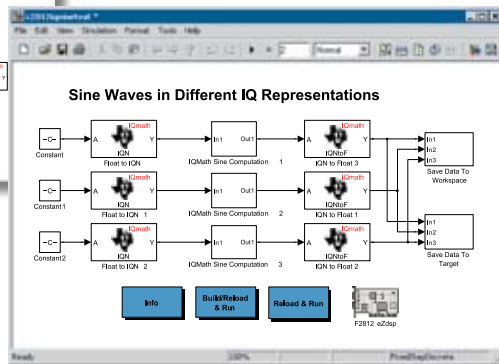
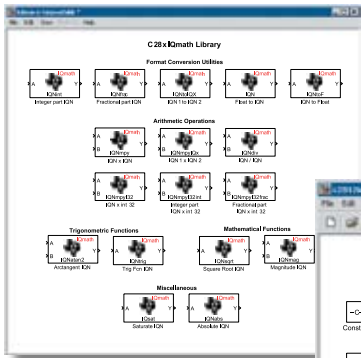

Computing sine waves using various IQMath representations from the C28x IQMath library.

Required Products

MathWorks Products

MATLAB

Simulink

Fixed-Point Toolbox

Link for Code Composer Studio

Real-Time Workshop

Signal Processing Blockset

Signal Processing Toolbox

Simulink Fixed Point

Texas Instruments Products

Code Composer Studio

Sample Tasks

Control the PWM duty cycle

Send and receive CAN message between target and host

Add a named RTDX input or RTDX output channel to Simulink models

Related Products

Real-Time Workshop Embedded Coder.

Generate production code for embedded systems

Simulink® Control Design. Design and analyze control systems in Simulink

Target for TI C6000™. Deploy embedded code onto TI C6000 processors

Supported Hardware

Target for TI C2000 supports the following boards:

- F2808 eZdsp
- F2812 eZdsp
- F2407 eZdsp

Platform and System Requirements

For platform and system requirements, visit www.mathworks.com/products/tic2000 ■

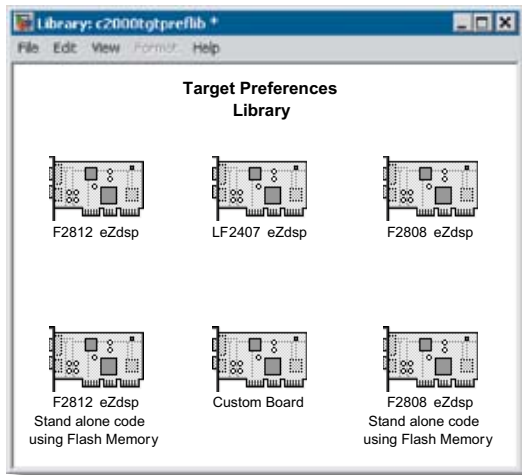

Target Preferences library used to preconfigure a model targeting either standard prototyping or custom boards that contain TI C2000 processors.

Resources

VISIT

www.mathworks.com

TECHNICAL SUPPORT

www.mathworks.com/support

ONLINE USER COMMUNITY

www.mathworks.com/matlabcentral

DEMOS

www.mathworks.com/demos

TRAINING SERVICES

www.mathworks.com/training

THIRD-PARTY PRODUCTS AND SERVICES

www.mathworks.com/connections

WORLDWIDE CONTACTS

www.mathworks.com/contact

E-MAIL

info@mathworks.com