

# Integral Anti-Windup for PI Controllers

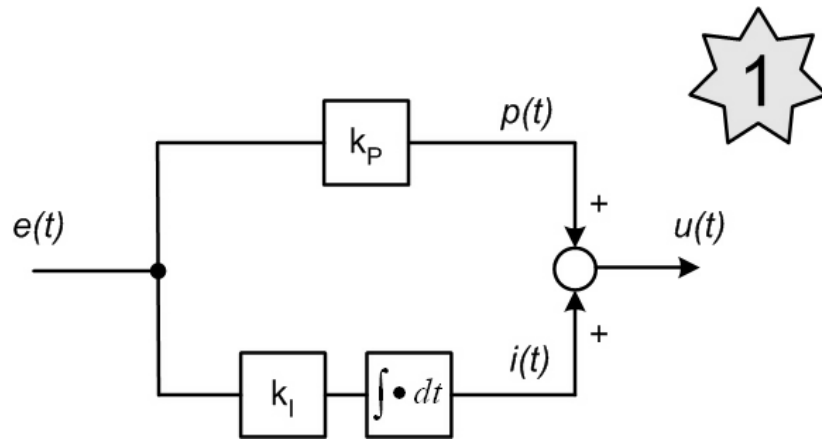

Fig. 1: Linear PI controller

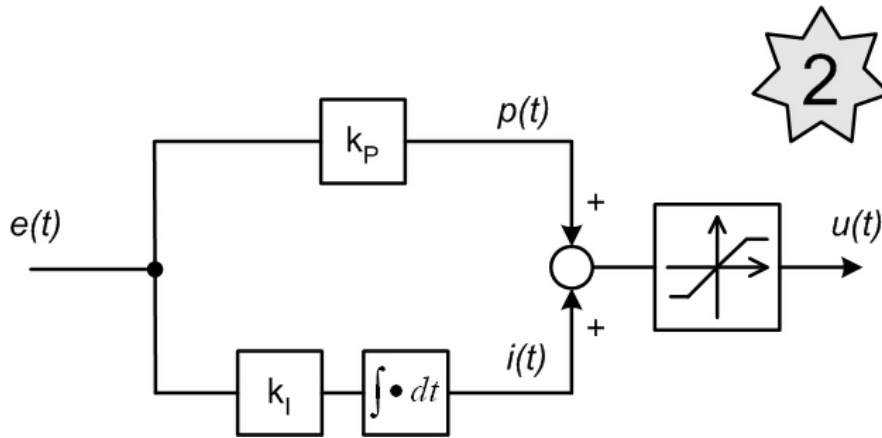

Fig. 2: Actuator saturation  $\rightarrow$  integrator wind-up phenomenon (discussed in detail in [6])

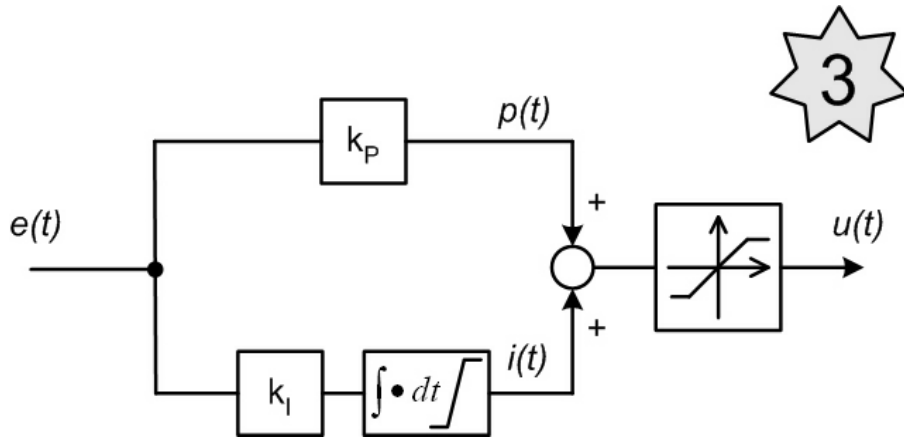

Fig. 3: Limited integrator (hard limits imposed)  $\rightarrow$  conditional integrator, integrator clamping [5][3]

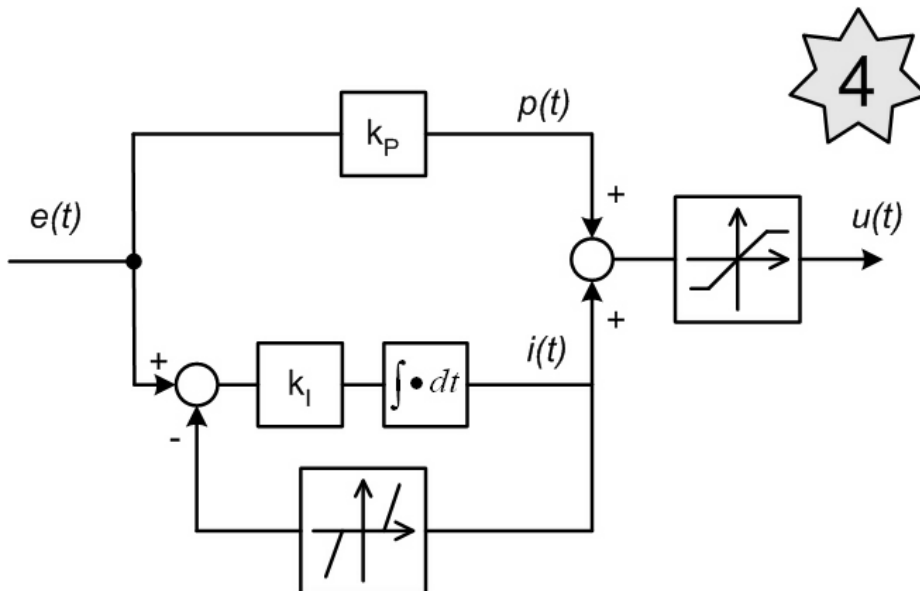

Fig. 4: Limited integrator (high feedback gain  $\rightarrow$  Scheme 3) [4][1]

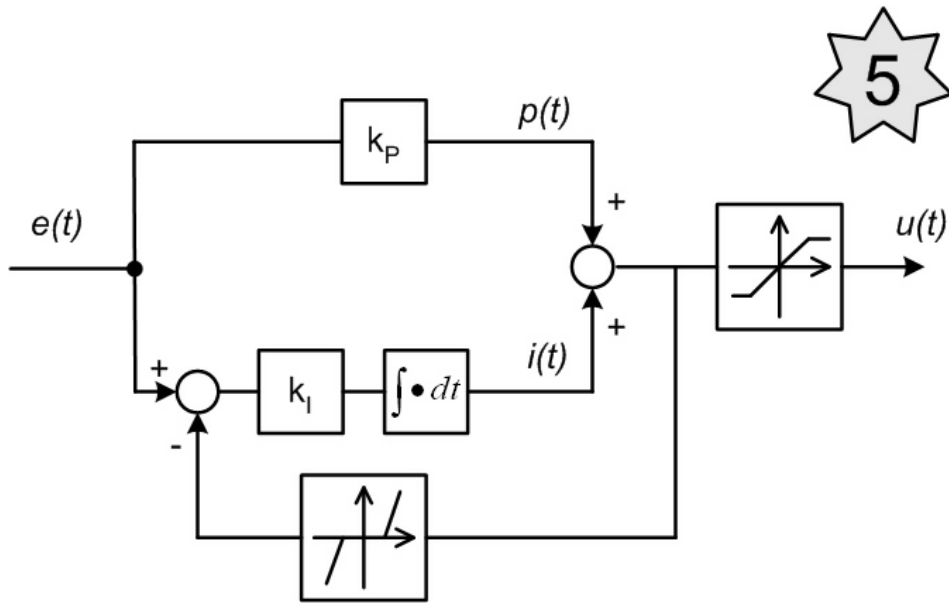

Fig. 5: Tracking anti-windup [4][1][2]

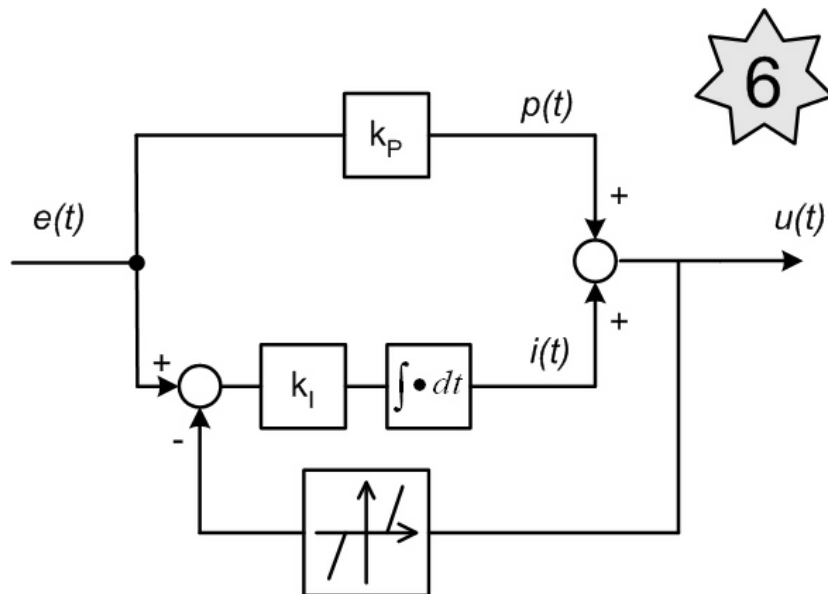

Fig. 6: Tracking anti-windup with unrestricted control signal (for actuators described by linear dynamics followed by a saturation) [4][1]

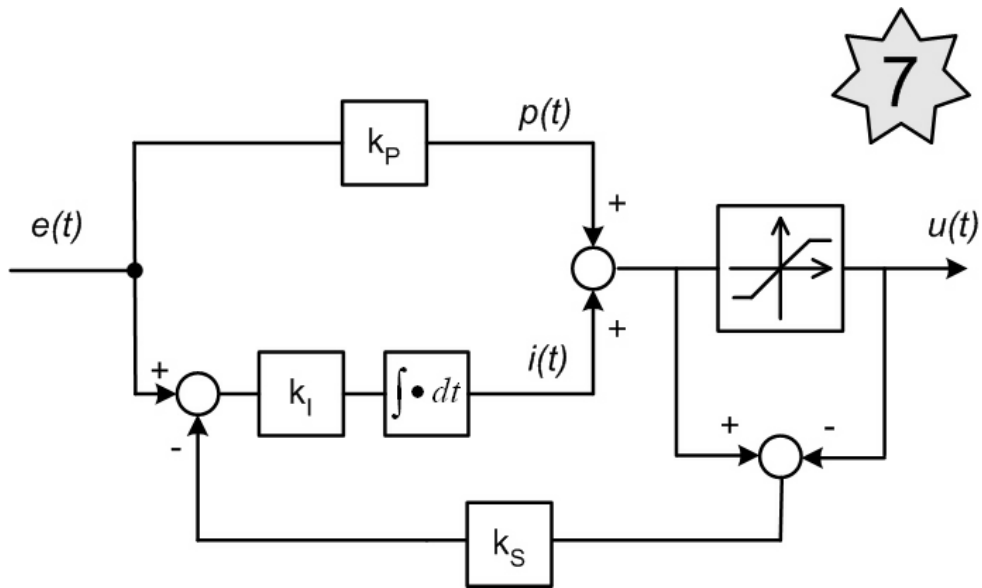

Fig. 7: Tracking anti-windup, back-calculation (equivalent to Scheme 5) [4][1]

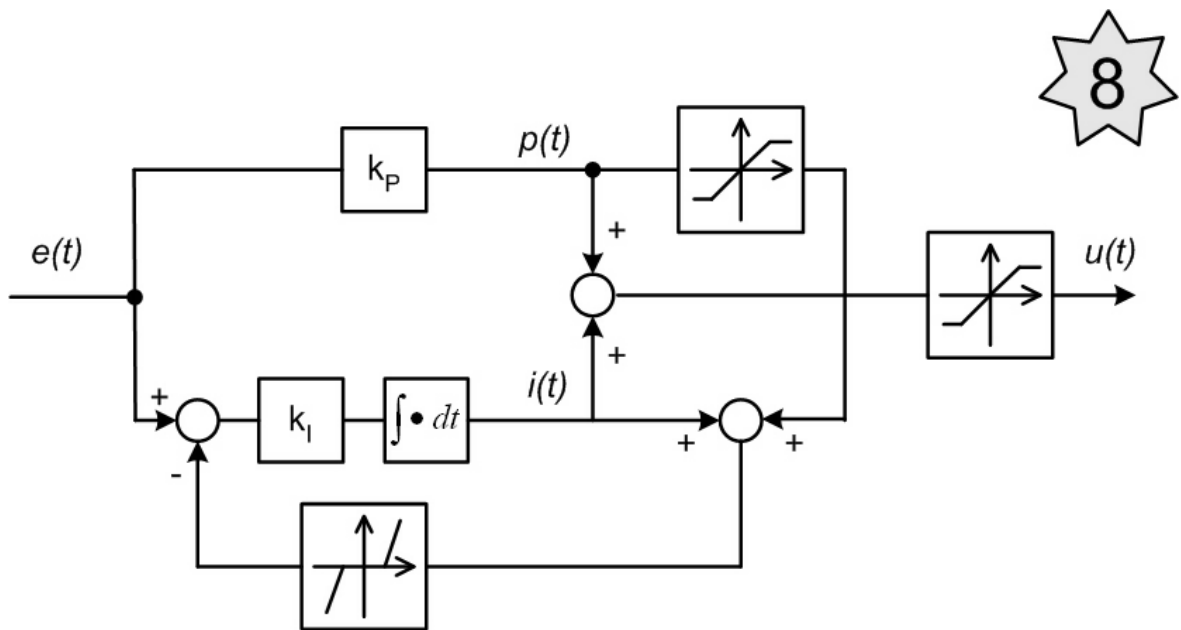

Fig. 8: Modified tracking anti-windup (introduction of an additional limit on the proportional part of the control signal used to generate the anti-windup-feedback signal) [4][1]

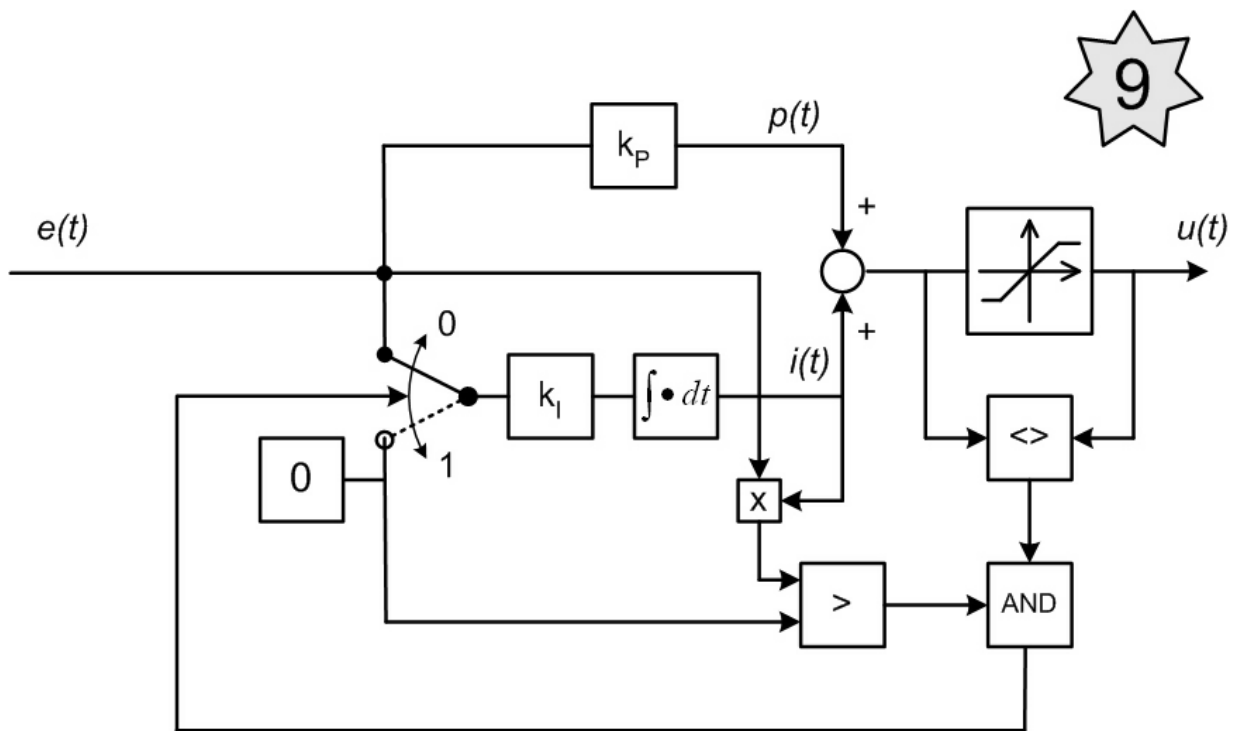

Fig. 9: Conditional integration ( $e(t) \cdot i(t) > 0$ )  $\rightarrow$  flexible limits (modified Scheme 3)

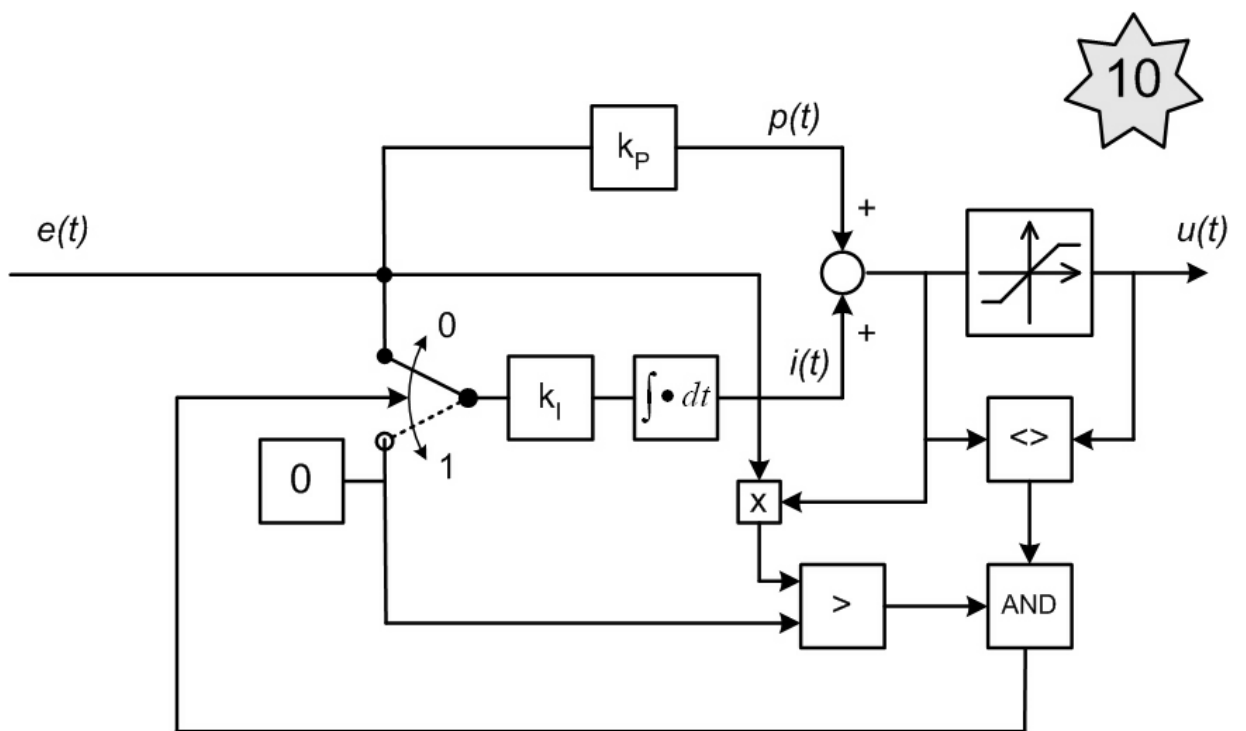
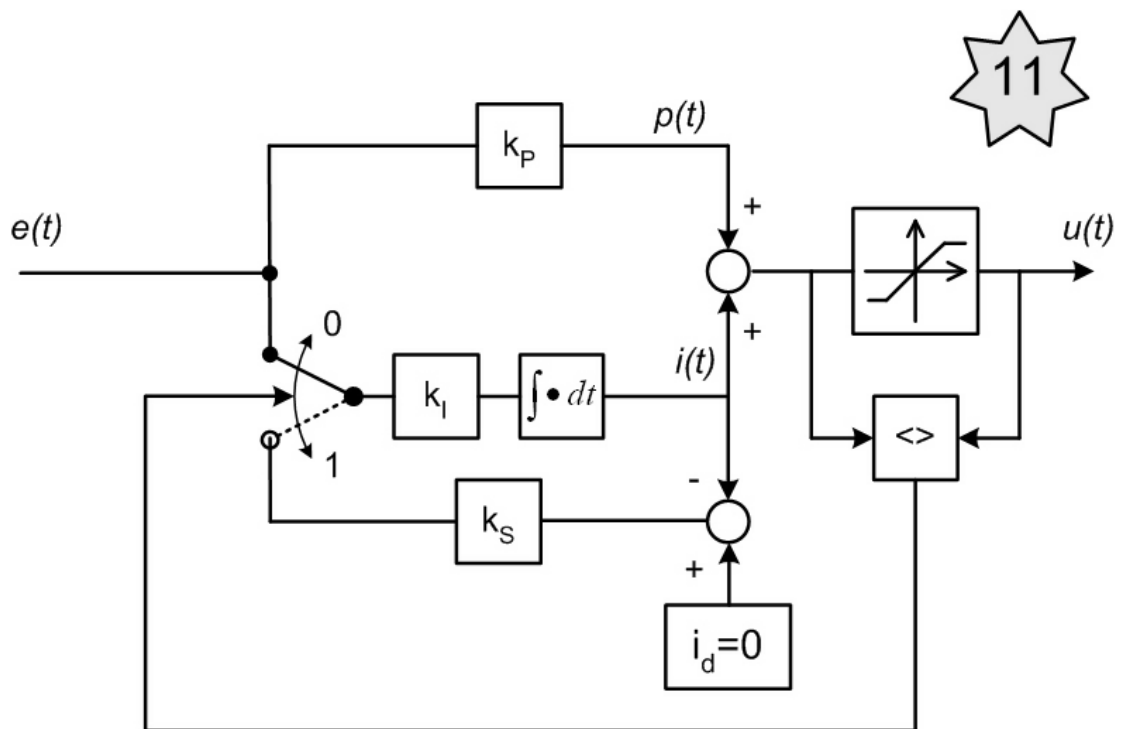

Fig. 10: Integrator clamping ( $e(t) \cdot u(t) > 0$ ) → found to be the best [5][3]



11

Fig. 11: Preloading  $\equiv$  The integrator output  $i(t)$  is dynamically (bumpless transfer protection) driven to the offline predetermined value  $i_d$  [3]

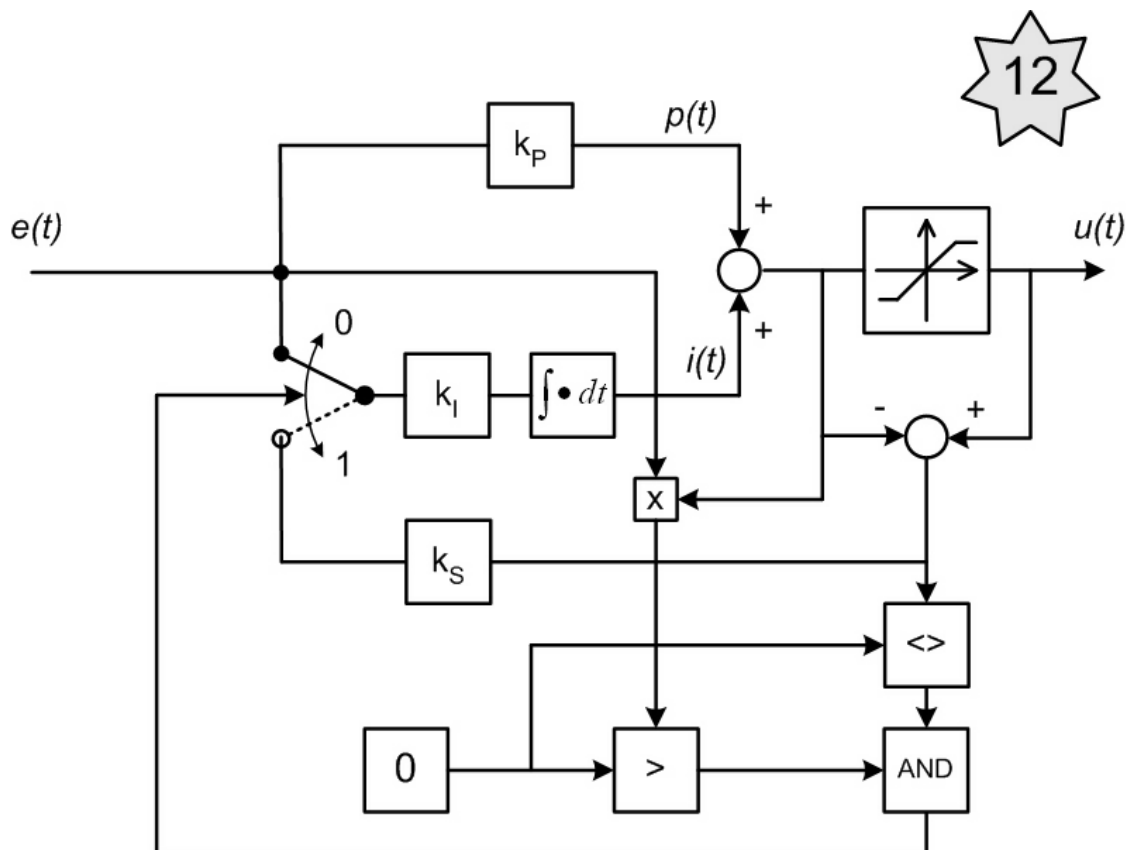

Fig. 12: Integral part variable limit (algorithm dynamically drives the integrator so that  $p(t) + i(t)$  lies at the edge of the saturation region), proposed in [3]

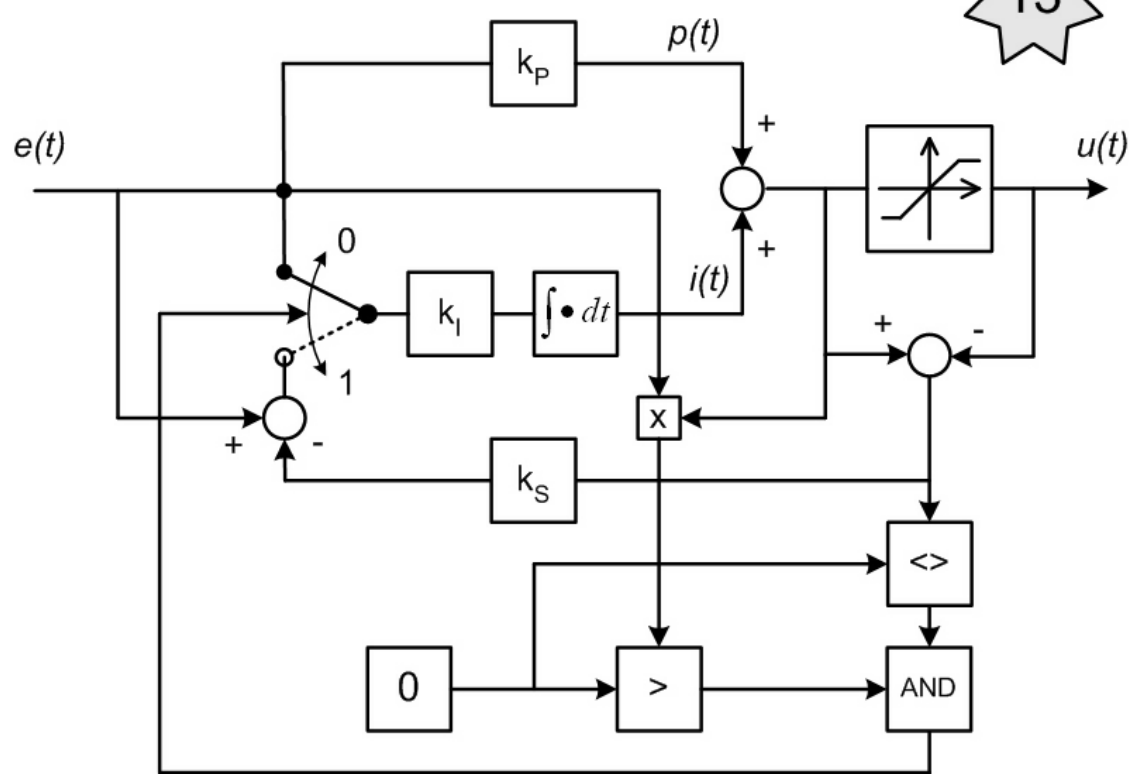

Fig. 13: Conditional integration combined with back-calculation approach (proposed in [5])

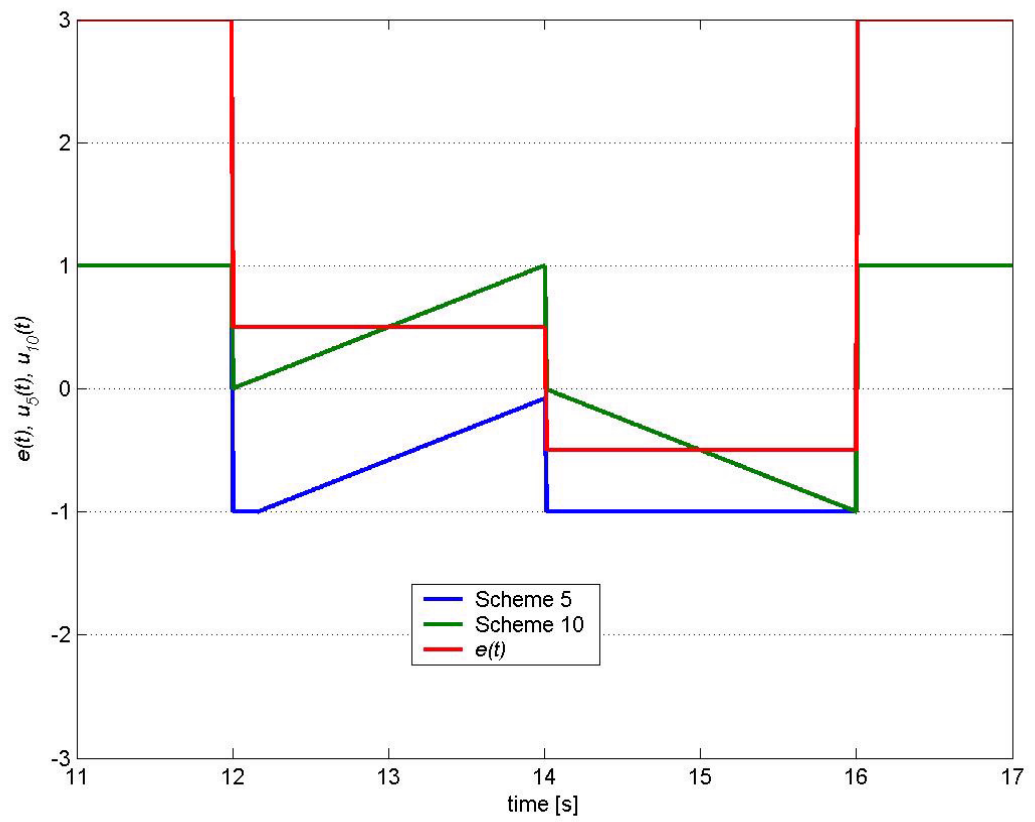

Fig. 14: Scheme 5 and Scheme 10 performance comparison

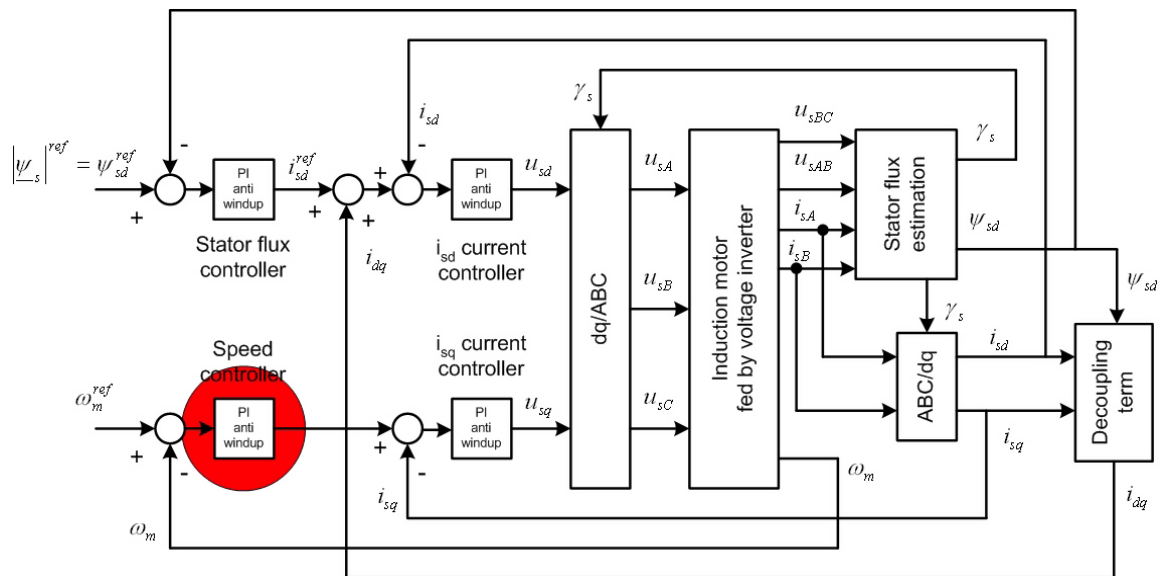

Fig. 15: Direct Stator Field Oriented Control scheme

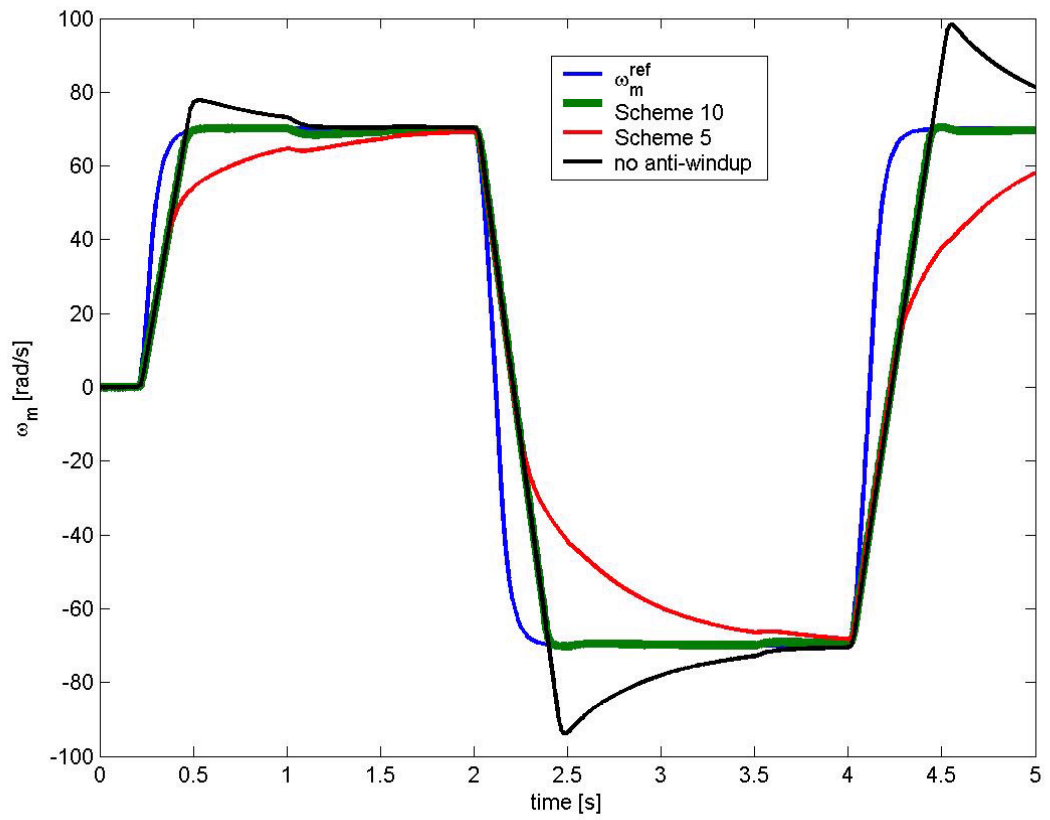

Fig. 16: Various DSFOC drive behaviour as a result of different PI anti-windup configuration

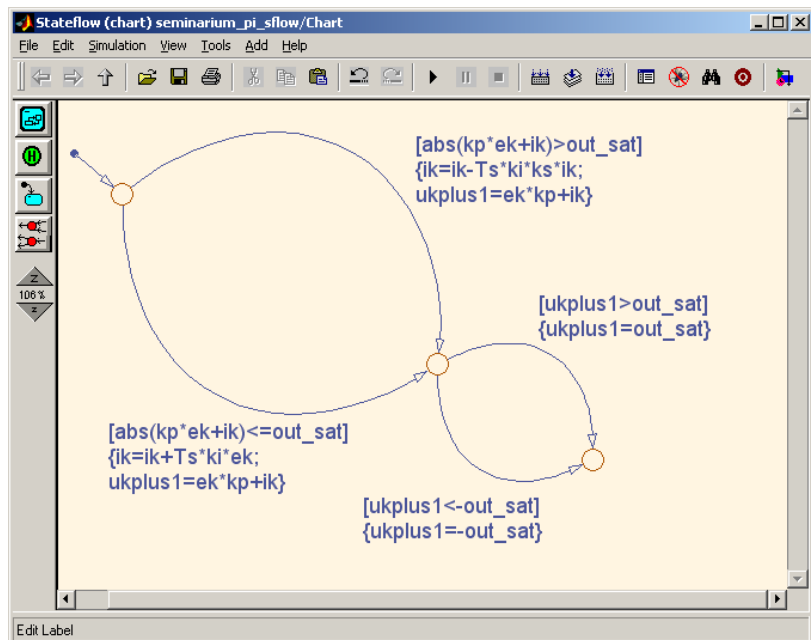

Fig. 17: Model in StateFlow<sup>®</sup> (Scheme 11)

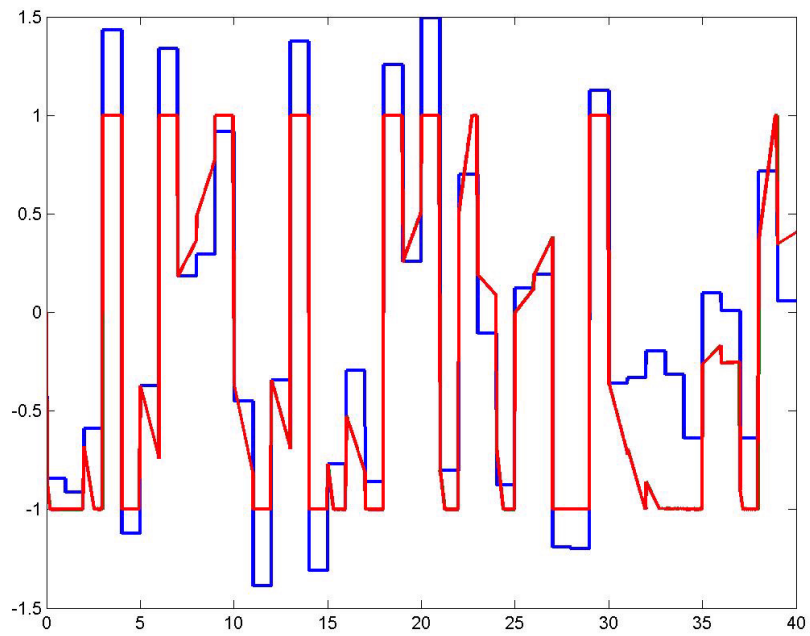

Fig. 18: Continuous states vs. discrete StateFlow<sup>®</sup>

## References

- [1] C. Bohm and D. P. Atherton. An analysis package comparing pid anti-windup strategies. *IEEE Systems Magazine*, 15(2):34–40, April 1995.
- [2] M. Hamdan and Zhiqiang Gao. A novel pid controller for pneumatic proportional valves with hysteresis. *IEEE Industry Applications Conference*, 2:1198–1201, October 2000.
- [3] A. Scottedward Hodel and C. E. Hall. Variable-structure pid control to prevent integrator windup. *IEEE Transactions on Industrial Electronics*, 48(2):442–451, April 2001.
- [4] M. Tharayil and A. Alleyne. A generalized pid error governing scheme for smart/sbli control. *IEEE American Control Conference*, 1:346–351, May 2002.
- [5] A. Visioli. Modified anti-windup scheme for pid controllers. *IEE Control Theory and Applications*, 150(1):49–54, January 2003.
- [6] D. Vrančič. *Design of Anti-Windup and bumpless Transfer Protection*. PhD thesis, University of Ljubljana, Slovenia, 1997.